

Chapter 2 Free Response Questions

1)

Let $f(x) = 4x^3 - 3x - 1$.

- Find the x -intercepts of the graph of f .
- Write an equation for the tangent line to the graph of f at $x = 2$.
- Write an equation of the graph that is the reflection across the y -axis of the graph of f .

2)

Given the function f defined by $f(x) = 2x^3 - 3x^2 - 12x + 20$.

- Find the zeros of f .
- Write an equation of the line normal to the graph of f at $x = 0$.
- Find the x - and y -coordinates of all points on the graph of f where the line tangent to the graph is parallel to the x -axis.

3)

Let f be the function defined by $f(x) = \begin{cases} 2x + 1, & \text{for } x \leq 2 \\ \frac{1}{2}x^2 + k, & \text{for } x > 2 \end{cases}$

- For what value of k will f be continuous at $x = 2$? Justify your answer.
- Using the value of k found in part (a), determine whether f is differentiable at $x = 2$. Use the definition of the derivative to justify your answer.
- Let $k = 4$. Determine whether f is differentiable at $x = 2$. Justify your answer.

4)

Let f be the function defined as follows:

$$f(x) = \begin{cases} |x-1| + 2, & \text{for } x < 1 \\ ax^2 + bx, & \text{for } x \geq 1, \text{ where } a \text{ and } b \text{ are constants.} \end{cases}$$

- (a) If $a = 2$ and $b = 3$, is f continuous for all x ? Justify your answer.
- (b) Describe all values of a and b for which f is a continuous function.
- (c) For what values of a and b is f both continuous and differentiable?

5)

Let f be the function given by $f(x) = \frac{2x-5}{x^2-4}$.

- a. Find the domain of f .
- b. Write an equation for each vertical and each horizontal asymptote for the graph of f .
- c. Find $f'(x)$.
- d. Write an equation for the line tangent to the graph of f at the point $(0, f(0))$.

6)

Let f and g and their inverses f^{-1} and g^{-1} be differentiable functions and let the values of f , g , and the derivatives f' and g' at $x = 1$ and $x = 2$ be given by the table below.

x	$f(x)$	$g(x)$	$f'(x)$	$g'(x)$
1	3	2	5	4
2	2	π	6	7

Determine the value of each of the following.

- (a) The derivative of $f + g$ at $x = 2$
- (b) The derivative of fg at $x = 2$
- (c) The derivative of $\frac{f}{g}$ at $x = 2$
- (d) $h'(1)$ where $h(x) = f(g(x))$
- (e) The derivative of g^{-1} at $x = 2$

7)

Consider the curve defined by the equation $y + \cos y = x + 1$ for $0 \leq y \leq 2\pi$.

- (a) Find $\frac{dy}{dx}$ in terms of y .
- (b) Write an equation for each vertical tangent to the curve.
- (c) Find $\frac{d^2y}{dx^2}$ in terms of y .

8)

Given the curve $x + xy + 2y^2 = 6$.

- (a) Find an expression for the slope of the curve at any point (x, y) on the curve.
- (b) Write an equation for the line tangent to the curve at the point $(2, 1)$.
- (c) Find the coordinates of all other points on this curve with slope equal to the slope at $(2, 1)$.

9)

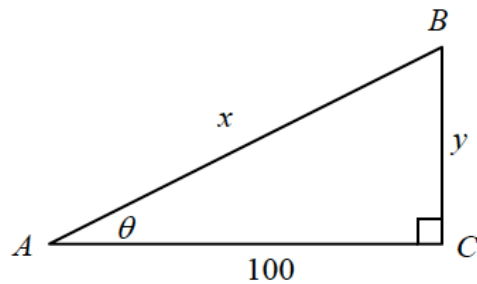

The figure above represents an observer at point A watching balloon B as it rises from point C . The balloon is rising at a constant rate of 3 meters per second and the observer is 100 meters from point C .

- (a) Find the rate of change in x at the instant when $y = 50$.
- (b) Find the rate of change in the area of right triangle BCA at the instant when $y = 50$.
- (c) Find the rate of change in θ at the instant when $y = 50$.

10)

The volume V of a cone $\left(V = \frac{1}{3} \pi r^2 h \right)$ is increasing at the rate of 28π cubic units per second. At the instant when the radius r of the cone is 3 units, its volume is 12π cubic units and the radius is increasing at $\frac{1}{2}$ unit per second.

- (a) At the instant when the radius of the cone is 3 units, what is the rate of change of the area of its base?
- (b) At the instant when the radius of the cone is 3 units, what is the rate of change of its height h ?

11)

Let f be the function defined by $f(x) = -2 + \ln(x^2)$.

- (a) For what real numbers x is f defined?
- (b) Find the zeros of f .
- (c) Write an equation for the line tangent to the graph of f at $x = 1$.

12)

Let f be the function given by $f(x) = \ln \frac{x}{x-1}$.

- (a) What is the domain of f ?
- (b) Find the value of the derivative of f at $x = -1$.
- (c) Write an expression for $f^{-1}(x)$, where f^{-1} denotes the inverse function of f .

13)

A particle moves along the x -axis in such a way that at time $t > 0$ its position coordinate is $x = \sin(e^t)$.

- (a) Find the velocity and acceleration of the particle at time t .
- (b) At what time does the particle first have zero velocity?
- (c) What is the acceleration of the particle at the time determined in part (b)?

14)

A particle moves on the x -axis so that its position at any time $t \geq 0$ is given by $x(t) = 2te^{-t}$.

- (a) Find the acceleration of the particle at $t = 0$.
- (b) Find the velocity of the particle when its acceleration is 0.

15)

Let f be the function given by $f(x) = \frac{x}{\sqrt{x^2 - 4}}$.

- (a) Find the domain of f .
- (b) Write an equation for each vertical asymptote to the graph of f .
- (c) Write an equation for each horizontal asymptote to the graph of f .
- (d) Find $f'(x)$.

16)

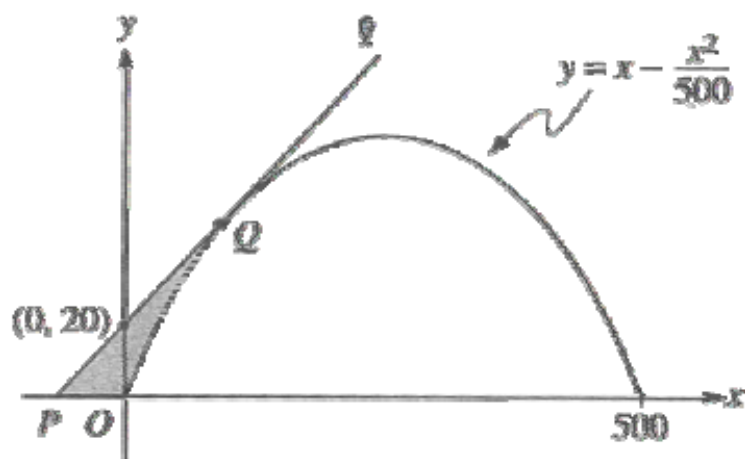

Line ℓ is tangent to the graph of $y = x - \frac{x^2}{500}$ at the point Q , as shown in the figure above.

- Find the x -coordinate of point Q .
- Write an equation for line ℓ .
- Suppose the graph of $y = x - \frac{x^2}{500}$ shown in the figure, where x and y are measured in feet, represents a hill. There is a 50-foot tree growing vertically at the top of the hill. Does a spotlight at point P directed along line ℓ shine on any part of the tree? Show the work that leads to your conclusion.

17)

Let f be the function given by $f(x) = \sqrt{x^4 - 16x^2}$.

- Find the domain of f .
- Describe the symmetry, if any, of the graph of f .
- Find $f'(x)$.
- Find the slope of the line normal to the graph of f at $x = 5$.

18)

Let f be the function that is given by $f(x) = \frac{ax + b}{x^2 - c}$ and that has the following properties.

- (i) The graph of f is symmetric with respect to the y -axis.
- (ii) $\lim_{x \rightarrow 2^+} f(x) = +\infty$
- (iii) $f'(1) = -2$

- (a) Determine the values of a , b , and c .
- (b) Write an equation for each vertical and each horizontal asymptote of the graph of f .
- (c) Sketch the graph of f in the xy -plane provided below.

19)

Consider the curve defined by $x^2 + xy + y^2 = 27$.

- (a) Write an expression for the slope of the curve at any point (x, y) .
- (b) Determine whether the lines tangent to the curve at the x -intercepts of the curve are parallel. Show the analysis that leads to your conclusion.
- (c) Find the points on the curve where the lines tangent to the curve are vertical.

20)

The radius r of a sphere is increasing at a constant rate of 0.04 centimeters per second.

- a.) At the time the radius of the sphere is 10 cm, what is the rate of increase of its volume?
- b.) At the time the volume of the sphere is 36π cubic cm, what is the rate of increase of the area of a cross section through the center of the sphere?
- c.) At the time when the volume and the radius of the sphere are increasing at the same numerical rate, what is the radius?

21)

Let p and q be real numbers and let f be the function defined by:

$$f(x) = \begin{cases} 1 + 2p(x-1) + (x-1)^2, & \text{for } x \leq 1 \\ qx + p, & \text{for } x > 1. \end{cases}$$

- (a) Find the value of q , in terms of p , for which f is continuous at $x = 1$.
- (b) Find the values of p and q for which f is differentiable at $x = 1$.
- (c) If p and q have the values determined in part (b), is f'' a continuous function? Justify your answer.

22)

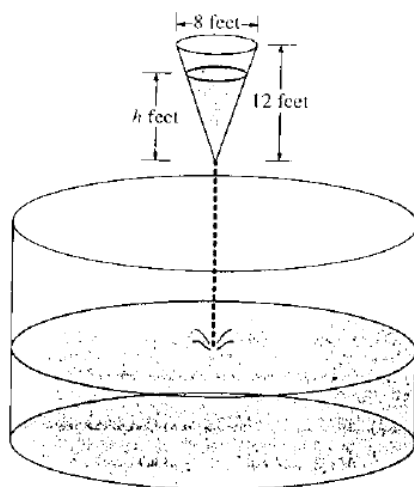

As shown in the figure above, water is draining from a conical tank with height 12 feet and diameter 8 feet into a cylindrical tank that has a base with area 400π square feet. The depth h , in feet, of the water in the conical tank is changing at the rate of $(h-12)$ feet per minute. (The volume V of a cone with radius r and height h is $V = \frac{1}{3}\pi r^2 h$.)

- (a) Write an expression for the volume of water in the conical tank as a function of h .
- (b) At what rate is the volume of water in the conical tank changing when $h = 3$? Indicate units of measure.
- (c) Let y be the depth, in feet, of the water in the cylindrical tank. At what rate is y changing when $h = 3$? Indicate units of measure.

23)

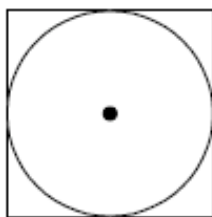

A circle is inscribed in a square as shown in the figure above. The circumference of the circle is increasing at a constant rate of 6 inches per second. As the circle expands, the square expands to maintain the condition of tangency. (Note: A circle with radius r has circumference $C = 2\pi r$ and area $A = \pi r^2$)

- Find the rate at which the perimeter of the square is increasing. Indicate units of measure.
- At the instant when the area of the circle is 25π square inches, find the rate of increase in the area enclosed between the circle and the square. Indicate units of measure.

24)

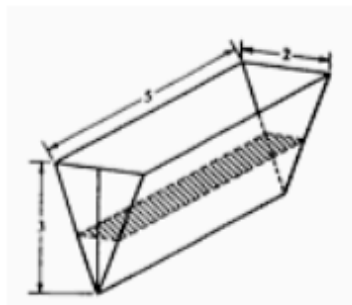

The trough shown in the figure above is 5 feet long, and its vertical cross sections are inverted isosceles triangles with base 2 feet and height 3 feet. Water is being siphoned out of the trough at the rate of 2 cubic feet per minute. At any time t , let h be the depth and V be the volume of water in the trough.

- Find the volume of water in the trough when it is full.
- What is the rate of change in h at the instant when the trough is $\frac{1}{4}$ full by volume?
- What is the rate of change in the area of the surface of the water (shaded in the figure) at the instant when the trough is $\frac{1}{4}$ full by volume?

25)

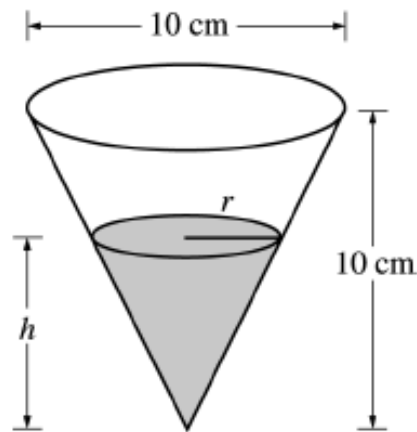

A container has the shape of an open right circular cone, as shown in the figure above. The height of the container is 10 cm and the diameter of the opening is 10 cm. Water in the container is evaporating so that its depth h is changing at the constant rate of $\frac{-3}{10}$ cm/hr.

(Note: The volume of a cone of height h and radius r is given by $V = \frac{1}{3}\pi r^2 h$.)

- Find the volume V of water in the container when $h = 5$ cm. Indicate units of measure.
- Find the rate of change of the volume of water in the container, with respect to time, when $h = 5$ cm. Indicate units of measure.
- Show that the rate of change of the volume of water in the container due to evaporation is directly proportional to the exposed surface area of the water. What is the constant of proportionality?

Answers APQ after 2.2

1)

- (a) Must solve $f(x) = 4x^3 - 3x - 1 = 0$. The polynomial can be factored by using long division or synthetic division. Possible rational zeros are $\pm 1, \pm \frac{1}{4}, \pm \frac{1}{2}$. Since $f(1) = 4 - 3 - 1 = 0$, divide the polynomial by $x - 1$.

$$\begin{array}{r}
 4x^2 + 4x + 1 \\
 x-1 \overline{) 4x^3 - 3x - 1} \\
 \underline{4x^3 - 4x^2} \\
 + 4x^2 - 3x \\
 \underline{+ 4x^2 - 4x} \\
 x - 1
 \end{array}
 \qquad
 \begin{array}{r|rrrr}
 1 & 4 & 0 & -3 & -1 \\
 & & 4 & 4 & 1 \\
 \hline
 & 4 & 4 & 1 & 0
 \end{array}$$

Therefore $f(x) = (x-1)(4x^2 + 4x + 1) = (x-1)(2x+1)^2$ and the x -intercepts are $x=1$ and $x=-\frac{1}{2}$.

- (b) $f'(x) = 12x^2 - 3$
 $f'(2) = 48 - 3 = 45$
 $f(2) = 25$

The equation of the tangent line is $y - 25 = 45(x - 2)$ or $y = 45x - 65$.

- (c) The reflection across the y -axis is given by $f(-x)$. So the equation is $y = f(-x) = 4(-x)^3 - 3(-x) - 1 = -4x^3 + 3x - 1$

2)

$$(a) \quad f(x) = 2x^3 - 3x^2 - 12x + 20 = (x-2)(2x^2 + x - 10) = 2(x-2)^2 \left(x + \frac{5}{2}\right)$$

The zeros of f are at $x = 2$ and $x = -\frac{5}{2}$.

$$(b) \quad f'(x) = 6x^2 - 6x - 12; \quad f'(0) = -12$$

The slope of the normal line is $m = -\frac{1}{f'(0)} = \frac{1}{12}$; $f(0) = 20$

The equation of the normal line is

$$y - 20 = \frac{1}{12}(x - 0), \text{ or } y = \frac{1}{12}x + 20, \text{ or } 12y = x + 240$$

(c) The tangent line will be parallel to the x -axis if the slope is 0.

$$f'(x) = 0 \Rightarrow 6x^2 - 6x - 12 = 0$$

$$6(x-2)(x+1) = 0 \Rightarrow x = 2, -1$$

$$f(-1) = 27 \text{ and } f(2) = 0$$

The coordinates are $(-1, 27)$ and $(2, 0)$.

3)

(a) $f(2) = 5$

$$\lim_{x \rightarrow 2^-} (2x + 1) = 5$$

$$\lim_{x \rightarrow 2^+} \left(\frac{1}{2}x^2 + k \right) = 2 + k$$

For continuity at $x = 2$, we must have $2 + k = 5$, and so $k = 3$.

(b) We compute $\lim_{x \rightarrow 2} \frac{f(x) - f(2)}{x - 2}$:

$$\lim_{x \rightarrow 2^-} \frac{2x + 1 - 5}{x - 2} = 2$$

$$\lim_{x \rightarrow 2^+} \frac{\frac{1}{2}x^2 + 3 - 5}{x - 2} = 2$$

So $f'(2)$ exists and $f'(2) = 2$

(c) When $k = 4$,

$$\lim_{x \rightarrow 2^+} f(x) = \lim_{x \rightarrow 2^+} \left(\frac{1}{2}x^2 + 4 \right) = 6$$

Hence f is not continuous at $x = 2$ and so is not differentiable at $x = 2$.

4)

(a) No, f is not continuous for all x since it is not continuous at $x = 1$.

$$\lim_{x \rightarrow 1^-} f(x) = 2, f(1) = 5$$

$$\therefore \lim_{x \rightarrow 1^-} f(x) \neq f(1)$$

or

$$\lim_{x \rightarrow 1^-} f(x) = 2, \lim_{x \rightarrow 1^+} f(x) = 5$$

$$\therefore \lim_{x \rightarrow 1^-} f(x) \neq \lim_{x \rightarrow 1^+} f(x)$$

(b) $f(1) = a + b$

or

$$\lim_{x \rightarrow 1^+} f(x) = a + b$$

The function f is continuous when $a + b = 2$.

$$(c) f'(x) = \begin{cases} -1 & \text{if } x < 1 \\ 2ax + b & \text{if } x > 1 \end{cases}$$

To be continuous and differentiable at $x = 1$, must have

$$a + b = 2$$

$$2a + b = -1$$

Therefore $a = -3$ and $b = 5$.

5)

a	$x \neq 2, x \neq -2$
b	VA @ $x = 2, x = -2$ HA @ $y = 0$
c	$f'(x) = \frac{-2(x-4)(x-1)}{(x^2-4)^2}$
d	$y - \frac{5}{4} = -\frac{1}{2}(x-0)$

6)

(a) $(f + g)'(2) = f'(2) + g'(2) = 6 + 7 = 13$

(b) $(fg)'(2) = f(2)g'(2) + f'(2)g(2) = 2 \cdot 7 + 6 \cdot \pi = 14 + 6\pi$

(c) $\left(\frac{f}{g}\right)'(2) = \frac{g(2)f'(2) - f(2)g'(2)}{(g(2))^2} = \frac{\pi \cdot 6 - 2 \cdot 7}{\pi^2} = \frac{6\pi - 14}{\pi^2}$

(d) $(f \circ g)'(1) = f'(g(1))g'(1) = f'(2) \cdot 4 = 6 \cdot 4 = 24$

(e) $h = g^{-1}(g(h))$. Therefore $1 = (g^{-1})'(g(h)) \cdot g'(h)$. Let $h = 1$. Then

$$1 = (g^{-1})'(2) \cdot g'(1)$$

$$(g^{-1})'(2) = \frac{1}{g'(1)} = \frac{1}{4}$$

7)

$$(a) \frac{dy}{dx} - \sin y \frac{dy}{dx} = 1$$

$$\frac{dy}{dx}(1 - \sin y) = 1$$

$$\frac{dy}{dx} = \frac{1}{1 - \sin y}$$

$$(b) \frac{dy}{dx} \text{ undefined when } \sin y = 1$$

$$y = \frac{\pi}{2}$$

$$\frac{\pi}{2} + 0 = x + 1$$

$$x = \frac{\pi}{2} - 1$$

$$(c) \frac{d^2y}{dx^2} = \frac{d\left(\frac{1}{1 - \sin y}\right)}{dx}$$

$$= \frac{-\left(-\cos y \frac{dy}{dx}\right)}{(1 - \sin y)^2}$$

$$= \frac{\cos y \left(\frac{1}{1 - \sin y}\right)}{(1 - \sin y)^2}$$

$$= \frac{\cos y}{(1 - \sin y)^3}$$

8)

(a) Implicit differentiation gives

$$x + xy + 2y^2 = 6$$

$$1 + x \frac{dy}{dx} + y + 4y \frac{dy}{dx} = 0$$

$$\frac{dy}{dx} = -\frac{1+y}{x+4y}$$

(b) At the point $(2,1)$, $\frac{dy}{dx} = -\frac{1+1}{2+4} = -\frac{1}{3}$. Therefore the equation of the tangent line is

$$y-1 = -\frac{1}{3}(x-2), \text{ or } y = -\frac{1}{3}x + \frac{5}{3}, \text{ or } 3y + x - 5 = 0.$$

(c)
$$-\frac{1+y}{x+4y} = -\frac{1}{3}$$

$$-1-y = -\frac{x}{3} - \frac{4y}{3}$$

$$\frac{x}{3} + \frac{y}{3} = 1$$

$$y = 3 - x$$

Substituting this into the equation for the curve gives

$$x + x(3-x) + 2(3-x)^2 = 6$$

$$x + 3x - x^2 + 18 - 12x + 2x^2 = 6$$

$$x^2 - 8x + 12 = 0$$

$$(x-6)(x-2) = 0$$

Therefore $x = 6$ is the only other point on the curve with the desired property. The coordinates at this point are $(6, -3)$.

9)

(a) $x^2 = y^2 + 100^2$

$$2x \frac{dx}{dt} = 2y \frac{dy}{dt}$$

At $y = 50$, $x = 50\sqrt{5}$ and $\frac{dx}{dt} = \frac{3 \cdot 50}{50\sqrt{5}} = \frac{3\sqrt{5}}{5}$ m/s

Explicitly: $x = \sqrt{y^2 + 100^2} \Rightarrow \frac{dx}{dt} = \frac{2y}{2\sqrt{y^2 + 100^2}} \frac{dy}{dt}$
 $= \frac{50}{\sqrt{12500}} (3)$
 $= \frac{3\sqrt{5}}{5}$ m/s

(b) $A = \frac{100y}{2} = 50y$

$$\frac{dA}{dt} = 50 \frac{dy}{dt} = 50 \cdot 3 = 150 \text{ m/s}$$

(c) $\tan \theta = \frac{y}{100}$

$$\sec^2 \theta \frac{d\theta}{dt} = \frac{1}{100} \frac{dy}{dt} = \frac{3}{100}$$

$$\frac{d\theta}{dt} = \frac{3}{100} \cos^2 \theta$$

At $y = 50$, $\cos \theta = \frac{100}{50\sqrt{5}}$ and therefore $\frac{d\theta}{dt} = \frac{3}{100} \left(\frac{2}{\sqrt{5}} \right)^2 = \frac{3}{125}$ radians/sec.

10)

(a) $A = \pi r^2$

When $r = 3$, $\frac{dA}{dt} = 2\pi r \frac{dr}{dt} = 2\pi \cdot 3 \cdot \frac{1}{2} = 3\pi$

(b) $V = \frac{1}{3} \pi r^2 h$

or $V = \frac{1}{3} Ah$

$$\frac{dV}{dt} = \frac{1}{3} \pi r^2 \frac{dh}{dt} + \frac{2}{3} \pi r h \frac{dr}{dt}$$

$$\frac{dV}{dt} = \frac{1}{3} A \frac{dh}{dt} + \frac{1}{3} h \frac{dA}{dt}$$

$$28\pi = \frac{1}{3} \pi (9) \frac{dh}{dt} + \frac{2}{3} \pi (3)(4) \left(\frac{1}{2} \right)$$

$$28\pi = \frac{1}{3} (9\pi) \frac{dh}{dt} + \frac{1}{3} 4(3\pi)$$

$$\frac{dh}{dt} = 8$$

$$\frac{dh}{dt} = 8$$

11)

(a) $f(x)$ is defined everywhere except $x = 0$

(b) The zeros are $\pm e$

(c) $y = 2x - 4$

12)

(a) $\frac{x}{x-1} > 0$

$x > 0$ and $x-1 > 0 \Rightarrow x > 1$

$x < 0$ and $x-1 < 0 \Rightarrow x < 0$

$x < 0$ or $x > 1$

(c) $y = \ln\left(\frac{x}{x-1}\right)$

$$e^y = \frac{x}{x-1}$$

$$x(e^y - 1) = e^y$$

$$x = \frac{e^y}{e^y - 1}$$

$$f^{-1}(x) = \frac{e^x}{e^x - 1}$$

(b) $f'(x) = \frac{x-1}{x} \cdot \frac{(x-1) - x}{(x-1)^2}$
 $= \frac{-1}{x(x-1)}$

or

$$\ln|x| - \ln|x-1| \Rightarrow f'(x) = \frac{1}{x} - \frac{1}{x-1}$$

$$f'(-1) = -\frac{1}{2}$$

13)

(a) $x = \sin(e^t)$

$$v = \frac{dx}{dt} = e^t \cos(e^t)$$

$$a = \frac{dv}{dt} = e^t(\cos(e^t) - e^t \sin(e^t))$$

(b) $v(t) = 0$ when $\cos(e^t) = 0$. Hence $e^t = \frac{\pi}{2}$ gives the first time when the velocity is zero, and so $t = \ln \frac{\pi}{2}$.

(c) $a\left(\ln \frac{\pi}{2}\right) = \frac{\pi}{2} \left(\cos \frac{\pi}{2} - \frac{\pi}{2} \sin \frac{\pi}{2} \right) = -\frac{\pi^2}{4}$

14)

- a. increasing on $[0, \frac{1}{2}]$ b. Abs max: $\left(\frac{1}{2}, \frac{1}{2e}\right)$
decreasing on $[\frac{1}{2}, 10]$ abs min. $(0, 0)$

15)

(a) $x < -2$ or $x > 2$
or $|x| > 2$

(b) $x = 2, x = -2$

(c) $\lim_{x \rightarrow \infty} \frac{x}{\sqrt{x^2 - 4}} = 1$

$$\lim_{x \rightarrow -\infty} \frac{x}{\sqrt{x^2 - 4}} = -1$$

$y = 1, y = -1$

(d)
$$f'(x) = \frac{\sqrt{x^2 - 4} - x \left[\frac{1}{2} (x^2 - 4)^{-1/2} 2x \right]}{x^2 - 4}$$
$$= \frac{\sqrt{x^2 - 4} - \frac{x^2}{\sqrt{x^2 - 4}}}{x^2 - 4}$$
$$= \frac{-4}{(x^2 - 4)^{3/2}}$$

16)

(a) Let Q be $\left(a, a - \frac{a^2}{500}\right)$

$$\frac{dy}{dx} = 1 - \frac{x}{250}$$

Setting slopes equal:

$$1 - \frac{a}{250} = \frac{\left(a - \frac{a^2}{500}\right) - 20}{a}$$

$$a = 100$$

(b) $y = \frac{3}{5}x + 20$

(c) Height of hill at $x = 250$: $y = 250 - \frac{250^2}{500}$
 $= 125$ feet

Height of line at $x = 250$: $y = \frac{3}{5}(250) + 20$
 $= 170$ feet

Yes, the spotlight hits the tree since the height of the line is less than the height of the hill + tree, which is 175 feet.

17)

(a) $x^4 - 16x^2 \geq 0$
 $x^2(x^2 - 16) \geq 0$
 $x^2 \geq 16$ or $x = 0$

The domain of f is all x satisfying $|x| \geq 4$ or $x = 0$.

(b) The graph of f is symmetric about the y -axis because $f(-x) = f(x)$.

(c) $f'(x) = \frac{1}{2}(x^4 - 16x^2)^{-1/2}(4x^3 - 32x)$
 $= \frac{2x(x^2 - 8)}{|x|\sqrt{x^2 - 16}}$

(d) $f'(5) = \frac{2 \cdot 125 - 16 \cdot 5}{\sqrt{625 - 16 \cdot 25}}$
 $= \frac{170}{15}$
 $= \frac{34}{3}$

Therefore the slope of the normal line is $m = -\frac{3}{34}$.

18)

(a) Graph symmetric to y -axis $\Rightarrow f$ is even

$$f(-x) = f(x) \text{ therefore } a = 0$$

$$\lim_{x \rightarrow 2^+} f(x) = +\infty \text{ therefore } c = 4$$

$$f(x) = \frac{b}{x^2 - 4}$$

$$f'(x) = \frac{-2bx}{(x^2 - 4)^2}$$

$$-2 = f'(1) = \frac{-2b}{9} \text{ therefore } b = 9$$

(b) $f(x) = \frac{9}{x^2 - 4}$

Vertical: $x = 2, x = -2$

Horizontal: $y = 0$

(c)

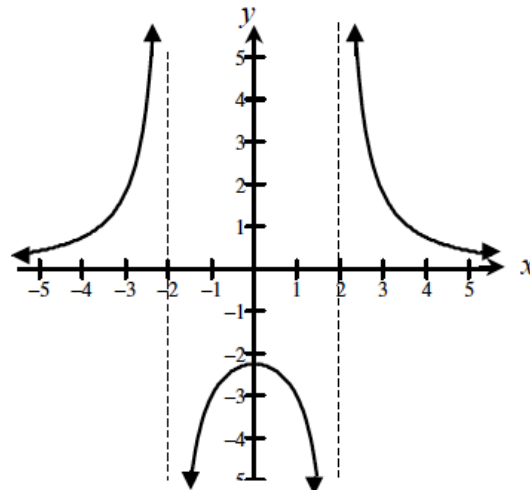

19)

(a) $2x + xy' + y + 2yy' = 0$

$$y' = \frac{-2x - y}{x + 2y}$$

(b) If $y = 0, x^2 = 27$

$$x = \pm 3\sqrt{3}$$

$$\text{at } x = 3\sqrt{3}, y' = \frac{-2 \cdot 3\sqrt{3}}{3\sqrt{3}} = -2$$

$$\text{at } x = -3\sqrt{3}, y' = \frac{2 \cdot 3\sqrt{3}}{-3\sqrt{3}} = -2$$

Tangent lines at x -intercepts are parallel.

(c) y' undefined if $x + 2y = 0$

$$(-2y)^2 + (-2y)y + y^2 = 27$$

$$3y^2 = 27$$

$$y = \pm 3$$

Points are $(-6, 3)$ and $(6, -3)$

20)

a. $\frac{dV}{dt}\Big|_{r=10} = 16\pi \text{ cm}^3/\text{sec}$

b. $\frac{dA}{dt}\Big|_{V=36\pi} = .24\pi \text{ cm}^2/\text{sec}$

c. $r = \frac{1}{2\sqrt{\pi}} \text{ cm}$

21)

(a) Must have $f(1) = \lim_{x \rightarrow 1} f(x)$ and $f(1) = 1$

$$\lim_{x \rightarrow 1^+} f(x) = p + q \text{ and } \lim_{x \rightarrow 1^-} f(x) = 1$$

Therefore $p + q = 1$

$$q = 1 - p$$

(b) $\lim_{x \rightarrow 1^-} f'(x) = 2p$

$$\lim_{x \rightarrow 1^+} f'(x) = q$$

So for $f'(1)$ to exist, $2p = q$

$f'(1)$ exists implies that f is continuous at $x = 1$. Therefore $q = 1 - p$.

Hence $2p = 1 - p$.

$$p = \frac{1}{3}, q = \frac{2}{3}.$$

(c) No, f'' is not a continuous function because it is not continuous at $x = 1$. This is because f'' is not defined at $x = 1$, or because $\lim_{x \rightarrow 1^-} f''(x) = 2$ and $\lim_{x \rightarrow 1^+} f''(x) = 0$.

22)

(a) $\frac{r}{h} = \frac{4}{12} = \frac{1}{3} \quad r = \frac{1}{3}h$

$$V = \frac{1}{3}\pi \left(\frac{1}{3}h\right)^2 h = \frac{\pi h^3}{27}$$

(b) $\frac{dV}{dt} = \frac{\pi h^2}{9} \frac{dh}{dt}$

$$= \frac{\pi h^2}{9} (h - 12) = -9\pi$$

V is decreasing at $9\pi \text{ ft}^3/\text{min}$

(c) Let W = volume of water in cylindrical tank

$$W = 400\pi y; \quad \frac{dW}{dt} = 400\pi \frac{dy}{dt}$$

$$400\pi \frac{dy}{dt} = 9\pi$$

y is increasing at $\frac{9}{400} \text{ ft/min}$

23)

a. $\frac{dP}{dt} = \frac{24}{\pi} \approx 7.639$ **in/sec**

b. $\left. \frac{dA}{dt} \right|_{A=25\pi} \approx 8.197$ **in²/sec**

24)

a. $V = 15$ **ft³**

b. $\left. \frac{dh}{dt} \right|_{V=\frac{15}{4}} = \frac{-2}{5}$ **ft/min**

c. $\left. \frac{dA_s}{dt} \right|_{V=\frac{15}{4}} = \frac{-4}{3}$ **ft²/min**

25)

a. $V = \frac{125}{12} \pi$ **cm³**

b. $\left. \frac{dV}{dt} \right|_{h=5, r=\frac{5}{2}} = -\frac{15}{8} \pi$ **cm³/hr**

c. $\frac{dV}{dt} = -\frac{3}{40} \pi h^2$; **Constant:** $-\frac{3}{10}$